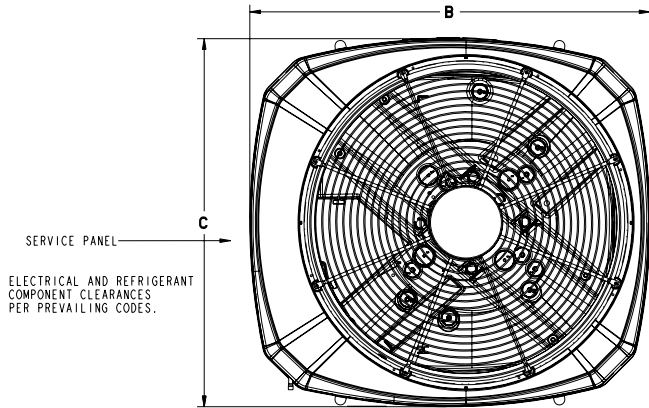

TAG: _____

SUBMITTAL

NOTE: All dimensions are in mm/inches.

4 Ton Split System Heat Pump — 1 Phase 2TWB0048A

 SERVICE PANEL
ELECTRICAL AND REFRIGERANT COMPONENT CLEARANCES PER PREVAILING CODES.

TOP DISCHARGE AREA SHOULD BE UNRESTRICTED FOR AT LEAST 1524 (5 FEET) ABOVE UNIT. UNIT SHOULD BE PLACED SO ROOF RUN-OFF WATER DOES NOT POUR DIRECTLY ON UNIT, AND SHOULD BE AT LEAST 305 (12") FROM WALL AND ALL SURROUNDING SHRUBBERY ON TWO SIDES. OTHER TWO SIDES UNRESTRICTED.

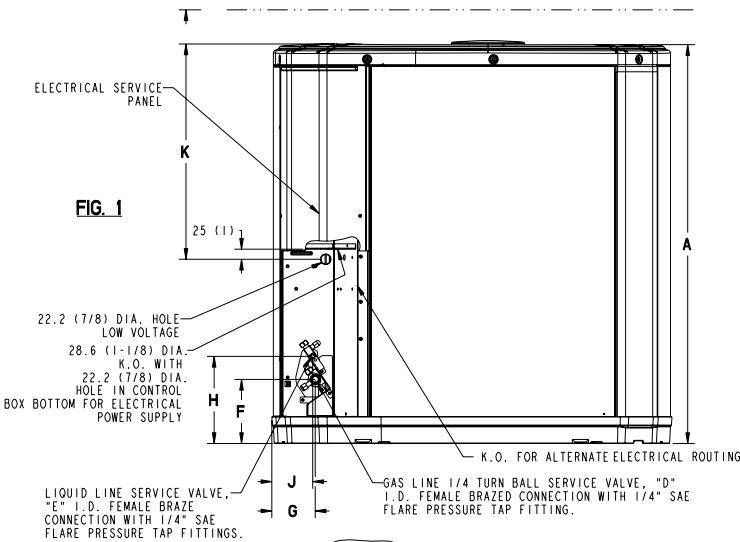
FIG. 1
FIG. 2

PRODUCT SPECIFICATIONS

OUTDOOR UNIT ①②	2TWB0048A1000C
POWER CONNS. — V/PH/HZ ③	200/230/1/60
MIN. BRCH. CIR. AMPACITY	26
BR. CIR. } MAX. (AMPS)	40
PROT. RTG. } MIN. (AMPS)	40
COMPRESSOR	CLIMATUFF®
NO. USED - NO. SPEEDS	1 - 1
VOLTS/PH/HZ	200/230/1/60
R.L. AMPS ⑦ - L.R. AMPS	9.6 - 71
FACTORY INSTALLED	
START COMPONENTS ⑧	NO
INSULATION/SOUND BLANKET	YES
COMPRESSOR HEAT	YES
OUTDOOR FAN	PROPELLER
DIA. (IN.) - NO. USED	23 - 1
TYPE DRIVE - NO. SPEEDS	DIRECT - 1
CFM @ 0.0 IN. W.G. ④	3675
NO. MOTORS - HP	1 - 1/4
MOTOR SPEED R.P.M.	825
VOLTS/PH/HZ	200/230/1/60
F.L. AMPS	1.9
OUTDOOR COIL — TYPE	SPINE FIN™
ROWS - F.P.I.	1 - 24
FACE AREA (SQ. FT.)	15.18
TUBE SIZE (IN.)	3/8
REFRIGERANT CONTROL	EXPANSION VALVE
REFRIGERANT	
LBS. — HCFC-22 (O.D. UNIT) ⑤	8 LBS. - 4 OZ.
FACTORY SUPPLIED	YES
LINE SIZE - IN. O.D. GAS ⑥	1-1/8
LINE SIZE - IN. O.D. LIQ. ⑥	3/8
FCCV	
RESTRICTOR ORIFICE SIZE	.083
DIMENSIONS	H X W X D
CRATED (IN.)	38 x 30.1 x 33
WEIGHT	
SHIPPING (LBS.)	255
NET (LBS.)	228

- ① Certified in accordance with the Air-Source Unitary Heat Pump Equipment certification program, which is based on ARI standard 210/240.
- ② Rated in accordance with ARI standard 270.
- ③ Calculated in accordance with Natl. Elec. Codes. Use only HACR circuit breakers or fuses.
- ④ Standard Air — Dry Coil — Outdoor
- ⑤ This value approximate. For more precise value see unit nameplate.
- ⑥ Max. linear length 80 ft.; Max. lift - Suction 60 ft.; Max lift - Liquid 60 ft. For greater length consult refrigerant piping software Pub. No. 32-3312-0* (* denotes latest revision).
- ⑦ This value shown for compressor RLA on the unit nameplate and on this specification sheet is used to compute minimum branch circuit ampacity and max. fuse size. The value shown is the branch circuit selection current.
- ⑧ No means no start components. Yes means quick start kit components. PTC means positive temperature coefficient starter.

MODELS	BASE	FIG.	A	B	C	D	E	F	G	H	J	K
2TWB0048A	3	1	832 (32-3/4)	829 (32-5/8)	756 (29-3/4)	1-1/8	3/8	143 (5-5/8)	92 (3-5/8)	210 (8-1/4)	79 (3-1/8)	508 (20)

Mechanical Specification Options

General

The 2TWB0 is fully charged from the factory for up to 15 feet of piping. This unit is designed to operate at outdoor ambient temperatures as high as 115°F. Cooling capacities are matched with a wide selection of air handlers and furnace coils that are A.R.I. certified. The unit is certified to UL 1995. Exterior is designed for outdoor application.

Casing

Unit casing is constructed of heavy gauge, G90 galvanized steel and painted with a weather-resistant powder paint

on all louvers, panels, prepaint on all other panels. Corrosion and weather-proof CMBP-G30 DuraTuff™ base.

Refrigerant Controls

Refrigeration system controls include condenser fan, compressor contactor and high pressure switch. High and low pressure controls are inherent to the compressor. A factory installed liquid line drier is standard.

Compressor

The Climatuff® compressor features internal over temperature and pressure protection and total dipped hermetic motor. Other features include: roto lock suction and discharge refrigerant connections, centrifugal oil pump and low vibration and noise.

Condenser Coil

The outdoor coil provides low airflow resistance and efficient heat transfer. The coil is protected on all four sides by louvered panels.

Low Ambient Cooling

As manufactured, this unit has a cooling capability to 55°F. The addition of an evaporator defrost control permits operation to 40° F. The addition of an evaporator defrost control with TXV permits low ambient cooling to 30° F.

Accessories

Thermostats — Cooling only and heat/cooling (manual and automatic changeover). Sub-base to match thermostat and locking thermostat cover.

Evaporator Defrost Control — See Low Ambient Cooling.



ARI Standard
210/240 UHP



Trane
www.trane.com

07/09

Trane has a policy of continuous product and product data improvement and it reserves the right to change design and specifications without notice.